

Please write clearly in block capitals.

Centre number

--	--	--	--	--

Candidate number

--	--	--	--

Surname

---

Forename(s)

---

Candidate signature

---

I declare this is my own work.

# GCSE MATHEMATICS

# F

Foundation Tier      Paper 3 Calculator

Monday 7 November 2022

Morning

Time allowed: 1 hour 30 minutes

## Materials

For this paper you must have:

- a calculator
- mathematical instruments
- the Formulae Sheet (enclosed).

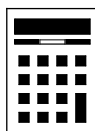

## Instructions

- Use black ink or black ball-point pen. Draw diagrams in pencil.
- Fill in the boxes at the top of this page.
- Answer **all** questions.
- You must answer the questions in the spaces provided. Do not write outside the box around each page or on blank pages.
- If you need extra space for your answer(s), use the lined pages at the end of this book. Write the question number against your answer(s).
- Do all rough work in this book. Cross through any work you do not want to be marked.

## Information

- The marks for questions are shown in brackets.
- The maximum mark for this paper is 80.
- You may ask for more answer paper, graph paper and tracing paper. These must be tagged securely to this answer book.

For Examiner's Use	
Pages	Mark
2–3	
4–5	
6–7	
8–9	
10–11	
12–13	
14–15	
16–17	
18–19	
20–21	
22–23	
24–25	
<b>TOTAL</b>	

## Advice

In all calculations, show clearly how you work out your answer.



Answer **all** questions in the spaces provided.

Do not write  
outside the  
box

**1** What is the **clockwise** turn from North to East?

Circle your answer.

[1 mark]

$45^\circ$

$90^\circ$

$270^\circ$

$315^\circ$

**2**  $d$  is 6 more than  $c$ .

Circle the correct equation.

[1 mark]

$$d = 6c$$

$$c = 6d$$

$$d = c + 6$$

$$c = d + 6$$

**3** Here is a number line.

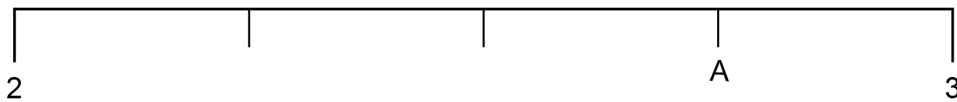

Which number is at A?

Circle your answer.

[1 mark]

2.3

2.55

2.6

2.75



- 4 In the quadrilateral, which angle is **obtuse**?

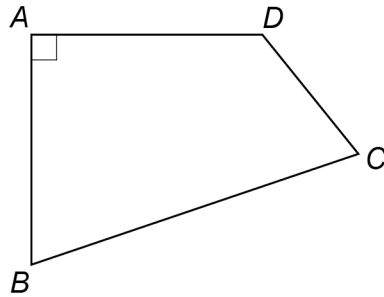

Circle your answer.

[1 mark]

*ADC*

*BAD*

*CBA*

*DCB*

- 5 (a) Write down the **two** prime numbers between 25 and 35

[2 marks]

Answer \_\_\_\_\_ and \_\_\_\_\_

- 5 (b) Write down **one** cube number between 100 and 300

[1 mark]

Answer \_\_\_\_\_



- 6 (a) Here are two straight lines.

Not drawn  
accurately

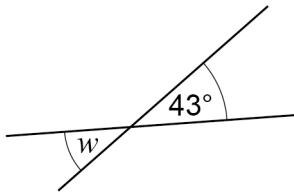

Write down the size of angle  $w$ .

[1 mark]

$w =$  \_\_\_\_\_ degrees

- 6 (b) Here are two different straight lines.

Not drawn  
accurately

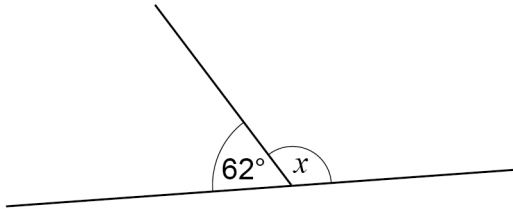

Work out the size of angle  $x$ .

[1 mark]

---



---

$x =$  \_\_\_\_\_ degrees

- 6 (c) In a triangle, two of the angles are  $51^\circ$  and  $74^\circ$ .

Work out the size of the third angle.

[1 mark]

---



---

Answer \_\_\_\_\_ degrees



7 (a) Solve  $12 - e = 0$

[1 mark]

---

$$e = \underline{\hspace{10em}}$$

7 (b) Solve  $7f = 0$

[1 mark]

---

$$f = \underline{\hspace{10em}}$$

8 Put these probabilities in order, starting with the **least** likely.

72%                  0.705                   $\frac{7}{10}$

[2 marks]

---

---

---

Answer                      ,                      ,                     

7
---

Turn over ►



9

$x$	0	2	4	6	8	
$y$	3	7	11		19	23

The  $x$ -values in the table make a linear sequence.

The  $y$ -values in the table make a different linear sequence.

9 (a) Complete the table.

[2 marks]

9 (b) Draw a straight line passing through the points (0, 3), (2, 7) and (4, 11)

[2 marks]

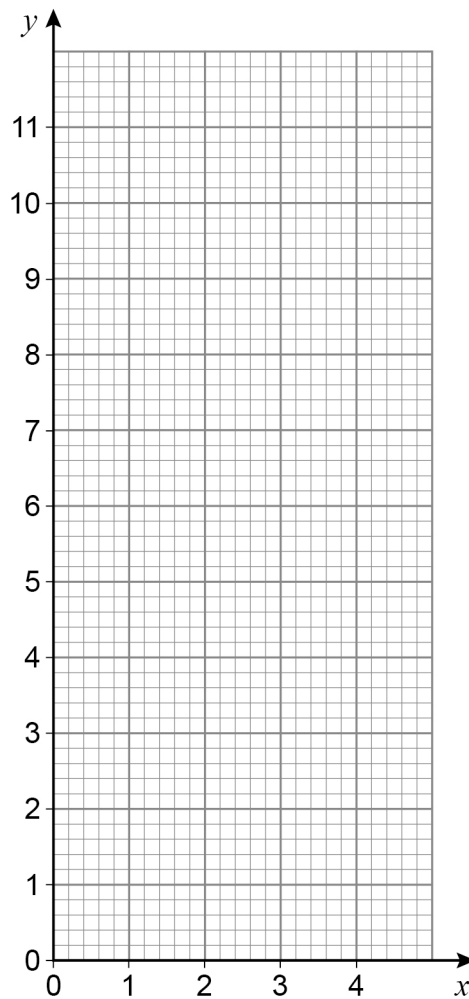

9 (c) Use the graph to work out the value of  $y$  when  $x = 3$

[1 mark]

$y =$  \_\_\_\_\_

10 (a)

When 5 is added to a negative number, the answer can be **positive**

Give **one** example to show that this is correct.

[1 mark]

---

---

10 (b)

When 5 is added to a negative number, the answer can be **negative**

Give **one** example to show that this is correct.

[1 mark]

---

---

10 (c)

When a number is doubled, the answer is always greater than the original number

Give **one** example to show that this is **not** correct.

[1 mark]

---

---



11

480 people are asked if they eat sushi.

20% say Yes.

 $\frac{2}{3}$  of the people who say Yes eat sushi at least once a month.

Complete the frequency tree.

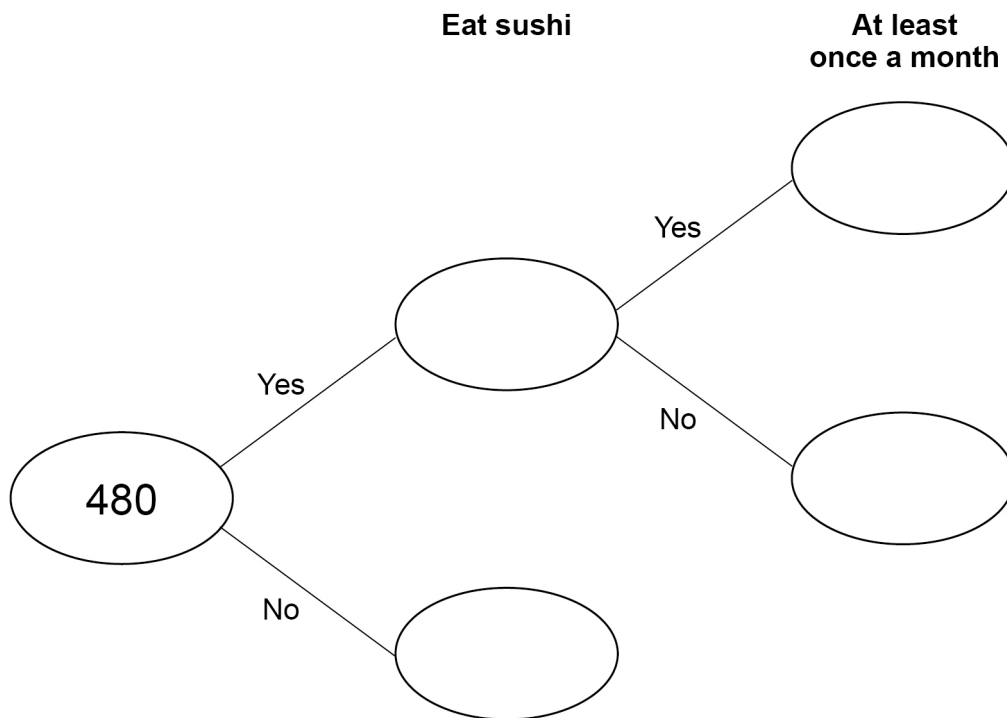
**[4 marks]**



14 Circle the solid that has six edges.

[1 mark]

triangular-based  
pyramid

sphere

cube

cylinder

15 (a) On the grid, shape A is shown.  
One side of shape B is also shown.

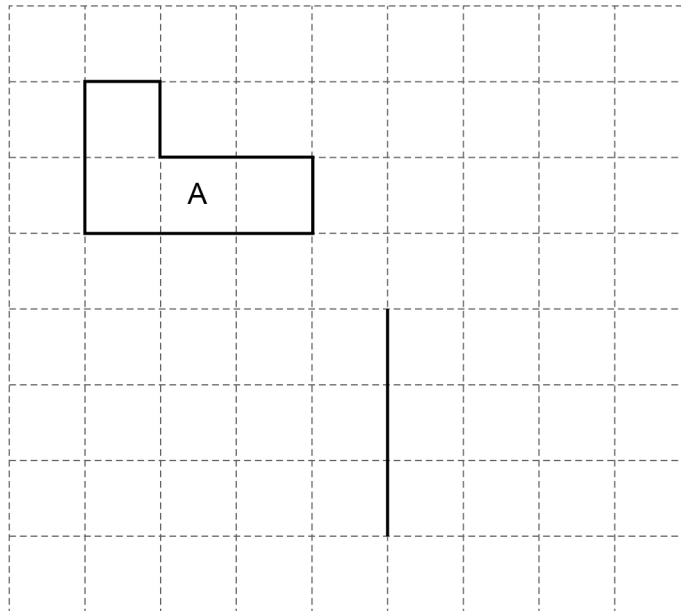

Complete shape B so that it is congruent to shape A.

[1 mark]



- 15 (b)** On this grid, shape C is shown.  
One side of shape D is also shown.

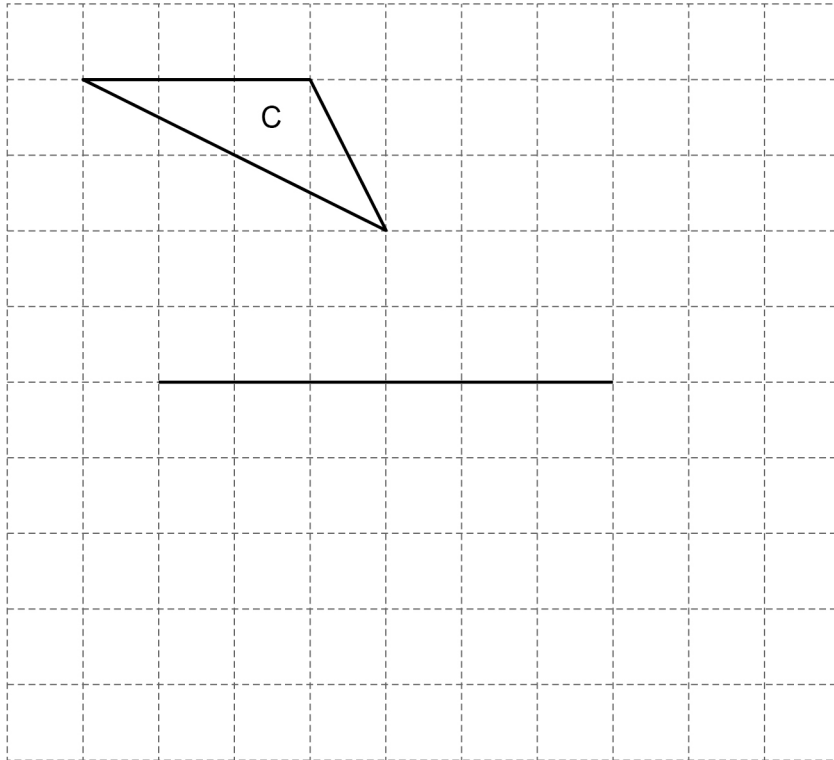

Complete shape D so that it is an enlargement of shape C with scale factor 2

**[1 mark]**

**Turn over for the next question**



- 16** 40 students were asked the number of visits they made to a gym one week.  
The chart shows information about the results.

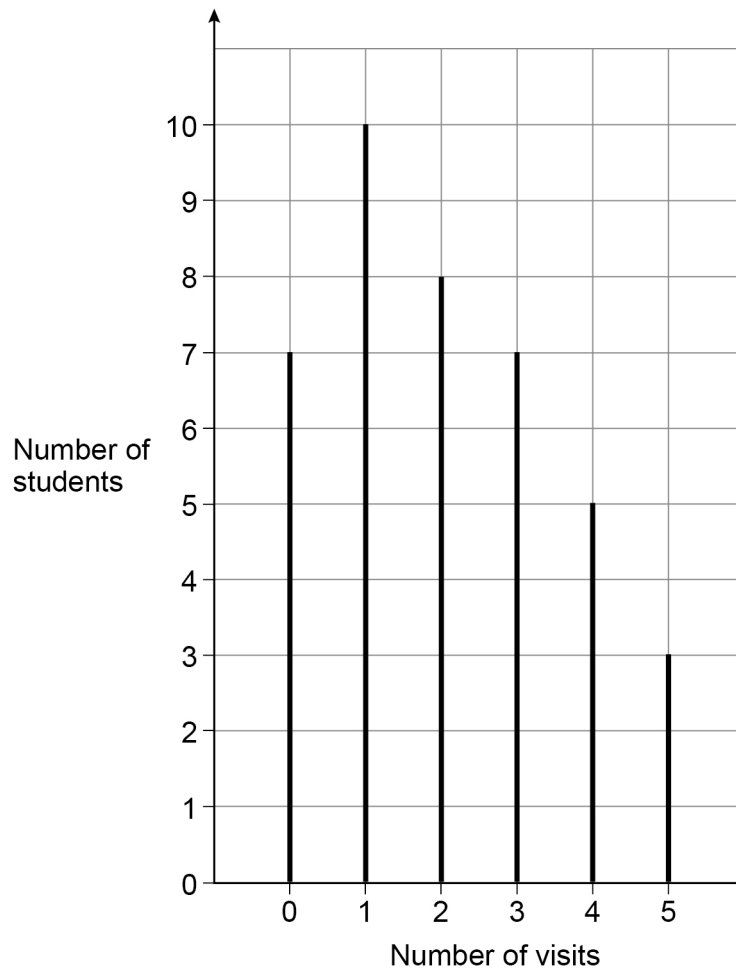

- 16 (a)** Write down the modal number of visits.

[1 mark]

Answer \_\_\_\_\_



- 16 (b)** Work out the mean number of visits.  
Give your answer as a decimal.

**[3 marks]**

---

---

---

---

---

---

---

---

Answer \_\_\_\_\_

- 16 (c)** One of the 40 students is chosen at random.  
Work out the probability that the student visited the gym **at least** once.

**[2 marks]**

---

---

---

Answer \_\_\_\_\_



- 17 This scale drawing of a bus has length 8 cm

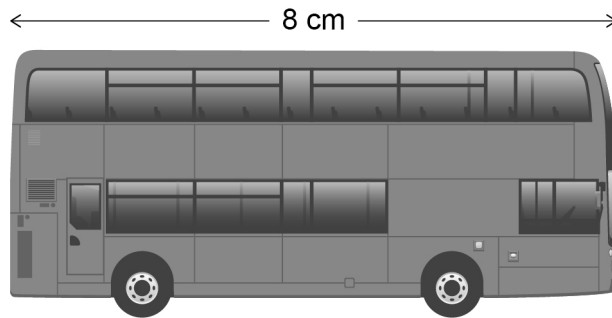

**Scale** 1 cm represents 1.65 m

The actual length of the bus is 3.8 times the actual length of a car.

Work out the actual length of the car.

Give your answer in metres, to the nearest centimetre.

**[3 marks]**

---

---

---

---

---

Answer \_\_\_\_\_ metres



- 18** 11 identical full tins of red paint hold a total of 3630 ml  
All the paint from 4 of these tins is poured into an empty bucket.  
The bucket can hold 2500 ml  
Tins of white paint each hold 140 ml  
Can all the white paint from 9 tins be added to the bucket?  
You **must** show your working.
- [4 marks]**

---

---

---

---

---

---

---

---

---

---

- 19** The largest possible value of  $n$  is 2  
Circle the correct inequality.
- [1 mark]**

$n \leq 2$

$n < 2$

$n \geq 2$

$n > 2$



**20** Jamil is on holiday in France.

**20 (a)** The cost of a room in a hostel is 27 euros.

Convert the cost to £

Use £1 = 1.2 euros

**[2 marks]**

---

---

---

Answer £ \_\_\_\_\_

**20 (b)** Jamil rides a motorbike.

The motorbike uses one litre of petrol for every 14 miles.

How many litres of petrol does the motorbike use to go 168 kilometres?

Use 8 kilometres = 5 miles

**[3 marks]**

---

---

---

---

---

---

---

Answer \_\_\_\_\_ litres



21 The scatter graph shows the height and mass of some dogs.

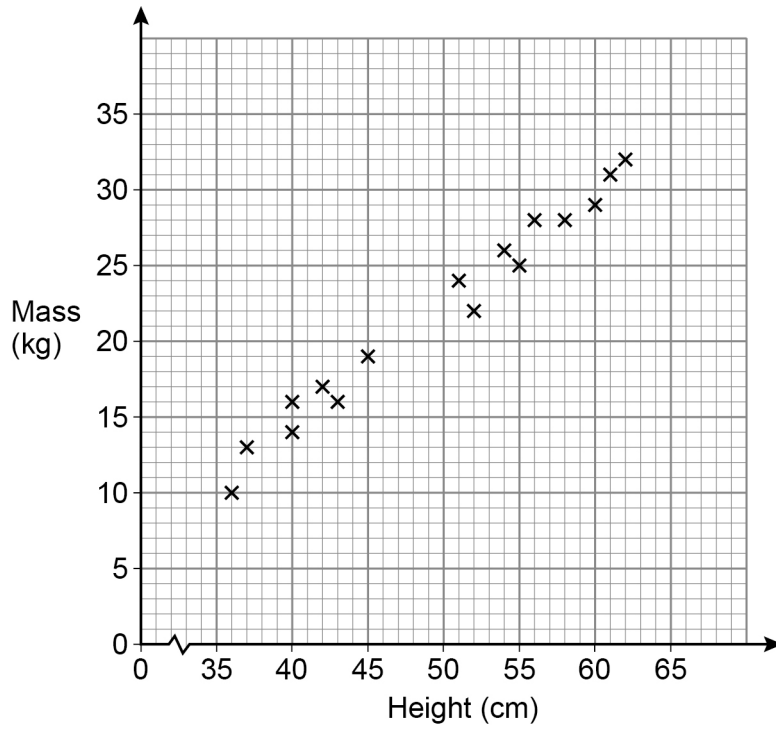

21 (a) The scatter graph shows positive correlation.

Describe the relationship between the height and mass of the dogs.

[1 mark]

---



---



---

21 (b) Use a line of best fit to estimate the mass of a dog with height 48 cm

[2 marks]

Answer \_\_\_\_\_ kg

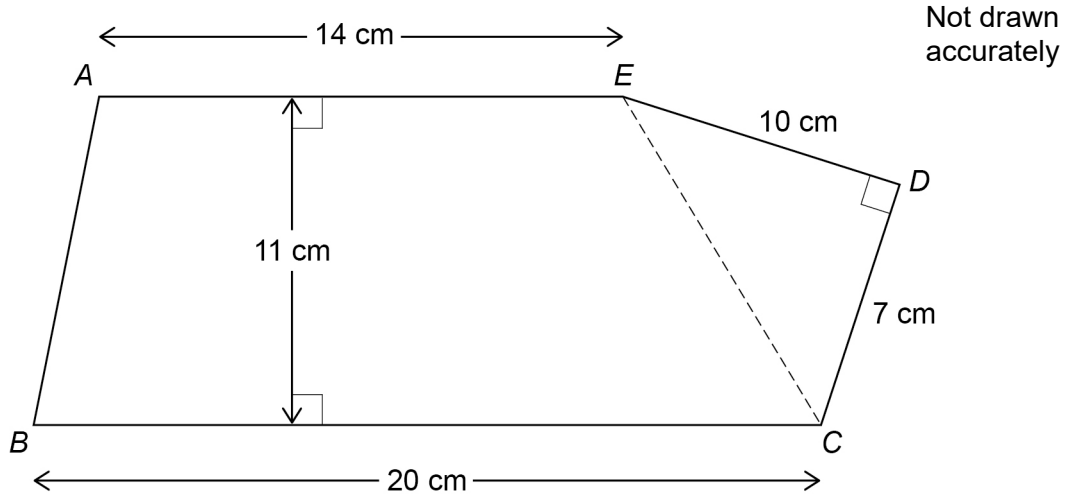

22

 $ABCDE$  is a pentagon.

Work out the area of the pentagon.

**[3 marks]**

---



---



---



---



---



---



---



---



---



---

Answer \_\_\_\_\_  $\text{cm}^2$ 



24

A solid statue has volume  $512 \text{ cm}^3$   
The statue has mass 3.6 kilograms.

density of iron = 7.87 grams per cubic centimetre

Is the statue made of iron?  
You **must** show your working.

[3 marks]

---

---

---

---

---

---

---

---

---

---



**25 (a)** Here is the rule for a sequence.

After the first two terms, each term is the sum of the previous two terms

The 1st term is 33

The 2nd term is  $x$

The 4th term is 73

Work out the value of  $x$ .

**[3 marks]**

---

---

---

---

---

---

---

---

$x =$  \_\_\_\_\_

**25 (b)** An expression for the  $n$ th term of a different sequence is  $n - n^2$

Ruth says,

“All the terms will be negative because  $n^2$  is always greater than  $n$ .”

Is she correct?

Tick a box.

Yes

No

Give a reason for your answer.

**[1 mark]**

---

---

---

7

**Turn over ►**



26

$P$  and  $Q$  are points.

The  $x$ -coordinate of  $Q$  is 4 **more** than the  $x$ -coordinate of  $P$ .

The  $y$ -coordinate of  $Q$  is 5 **less** than the  $y$ -coordinate of  $P$ .

Work out the gradient of the straight line through  $P$  and  $Q$ .

**[2 marks]**

---

---

---

---

Answer \_\_\_\_\_

27

$$m = pr$$

$p$  is halved and  $r$  is multiplied by 3

What happens to  $m$  ?

Circle your answer.

**[1 mark]**

$\times 6$

$\times \frac{1}{6}$

$\times \frac{3}{2}$

$\times \frac{2}{3}$



28 Here are the results after 250 spins of a coin.

<b>Heads</b>	128
<b>Tails</b>	122

The coin is spun an extra 50 times.

After all 300 spins, the relative frequency of Heads is 0.49

For the **extra 50 spins**, work out number of Heads : number of Tails

[3 marks]

---



---



---



---



---



---



---



---

Answer \_\_\_\_\_ : \_\_\_\_\_

29 Circle the equation where  $c$  is inversely proportional to  $d$ .

[1 mark]

$$c = \frac{1}{2}d$$

$$c = \frac{2}{d}$$

$$c = -2d$$

$$c = -\frac{2}{d^2}$$



30

Part of a running track is the arc of a semicircle joined to a straight line.

The semicircle has diameter 45 metres.

The straight line has length 75 metres.

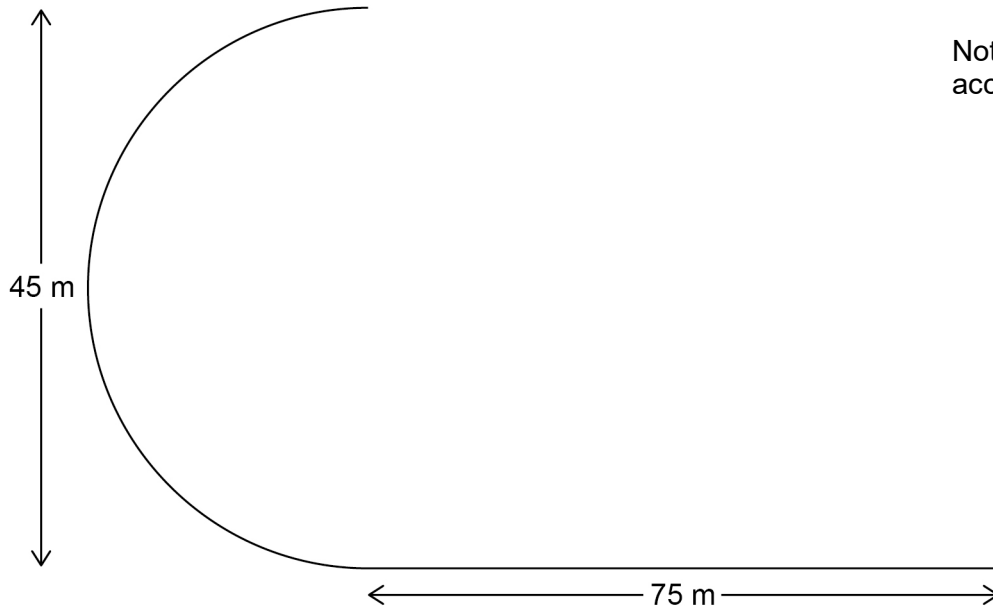

Abby runs once along this part of the track in 18 seconds.

Work out her average speed.

Give your answer to 2 significant figures.

[4 marks]

---

---

---

---

---

---

---

---

---

---

Answer \_\_\_\_\_ m/s



31

Here is some information about the members of clubs A and B.

	Number of members	Mean height of members
Club A	24	1.8 m
Club B	20	1.92 m

Work out  $\frac{\text{total height of the members of club A}}{\text{total height of the members of club B}}$

Give your answer as a decimal.

[2 marks]

---

---

---

---

---

---

---

Answer \_\_\_\_\_

**END OF QUESTIONS**

