

Please write clearly in block capitals.

Centre number

--	--	--	--	--

Candidate number

--	--	--	--

Surname

Forename(s)

Candidate signature

I declare this is my own work.

GCSE MATHEMATICS

H

Higher Tier

Paper 1 Non-Calculator

Time allowed: 1 hour 30 minutes

Materials

For this paper you must have:

- mathematical instruments

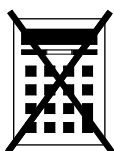

You must **not** use a calculator.

Instructions

- Use black ink or black ball-point pen. Draw diagrams in pencil.
- Fill in the boxes at the top of this page.
- Answer **all** questions.
- You must answer the questions in the spaces provided. Do not write outside the box around each page or on blank pages.
- If you need extra space for your answer(s), use the lined pages at the end of this book. Write the question number against your answer(s).
- Do all rough work in this book. Cross through any work you do not want to be marked.

Information

- The marks for questions are shown in brackets.
- The maximum mark for this paper is 80.
- You may ask for more answer paper, graph paper and tracing paper. These must be tagged securely to this answer book.

For Examiner's Use	
Pages	Mark
2–3	
4–5	
6–7	
8–9	
10–11	
12–13	
14–15	
16–17	
18–19	
20–21	
22–23	
24–25	
26	
TOTAL	

Advice

In all calculations, show clearly how you work out your answer.



Answer **all** questions in the spaces provided.

- 1 Simplify $(a^5)^3$
Circle your answer.

[1 mark]

$8a$

$15a$

a^8

a^{15}

- 2 $x \neq 0.4$
Circle the possible value of x .

[1 mark]

$\frac{4}{10}$

$\frac{20}{50}$

$\frac{26}{70}$

$\frac{120}{300}$

- 3 Circle the solid that has 7 vertices.

[1 mark]

hexagonal
prism

hexagon-based
pyramid

pentagonal
prism

pentagon-based
pyramid



- 4 Here is a sketch of a graph.

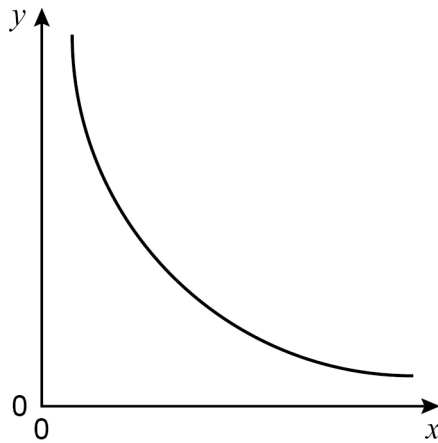

Circle the equation of the graph.

k is a constant.

[1 mark]

$$y = kx$$

$$y = k + x$$

$$y = k - x$$

$$y = \frac{k}{x}$$

- 5 Write 200 as a product of prime factors.
Give your answer in index form.

[3 marks]

Answer _____



- 6** Lily's age is 2 years and 4 months.
Hugo's age is 1 year and 8 months.
Write Lily's age in months as a fraction of Hugo's age in months.
Give your fraction in its simplest form. **[2 marks]**

Answer _____

- 7** Use approximations to estimate the answer to $\frac{\sqrt{97} + 2.014^3}{0.49}$ **[3 marks]**

Answer _____



8 (a) Solve $5x + 6 > 3x + 15$

[3 marks]

Answer _____

8 (b) Write down the inequality represented by the number line.



[2 marks]

Answer _____



9

The diagram shows an octagon.

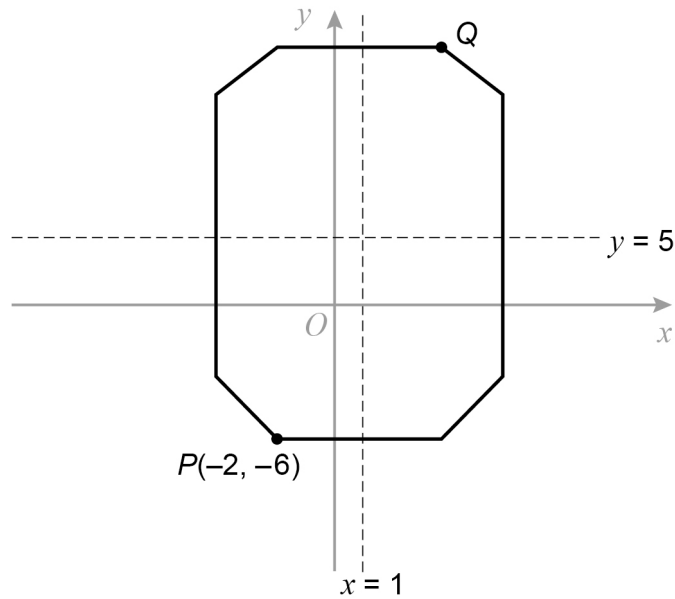
Not drawn
accurately

$x = 1$ and $y = 5$ are lines of symmetry.

Work out the coordinates of point Q.

[2 marks]

Answer (_____ , _____)



- 10 (a)** Work out $2000 \times 70\,000$
Give your answer in standard form.

[2 marks]

Answer _____

- 10 (b)** Work out $\frac{1.8 \times 10^2}{3 \times 10^{-1}}$
Give your answer as an ordinary number.

[2 marks]

Answer _____

6

Turn over ►



11 A , B , C and D are junctions on a motorway.

Not drawn
accurately



distance $CD = 3 \times$ distance AB

distance $BC = 25$ miles

Salma drives from A to C .

She drives for 30 minutes at an average speed of 62 miles per hour.

Work out the distance AD .

[4 marks]

Answer _____ miles



12 Here is a right-angled triangle.

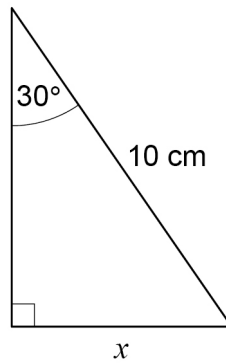

Not drawn
accurately

Use trigonometry to work out the value of x .

[3 marks]

Answer _____ cm

Turn over for the next question



13 Convert $\frac{5}{6}$ to a recurring decimal.

[2 marks]

Answer _____

14 Simplify $\frac{3}{x} + \frac{4}{x}$

Circle your answer.

[1 mark]

$$\frac{7}{x}$$

$$\frac{7}{2x}$$

$$\frac{12}{x}$$

$$\frac{12}{x^2}$$



- 16** The cumulative frequency graph represents the masses of 40 necklaces.

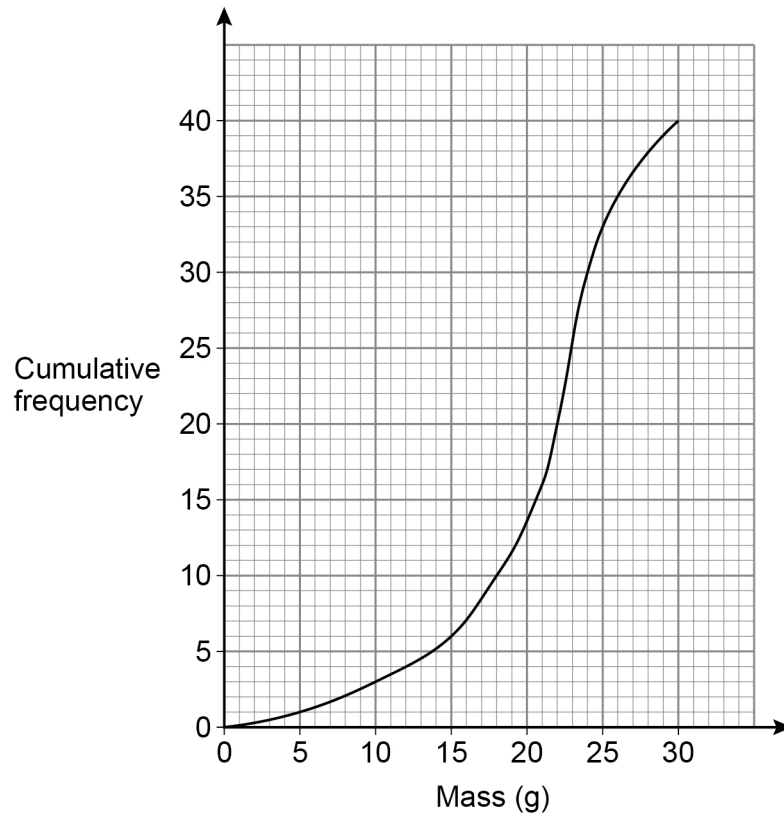

- 16 (a)** A jeweller buys every necklace with mass **greater than** 21 grams.

Use the graph to estimate how many she buys.

[2 marks]

Answer _____

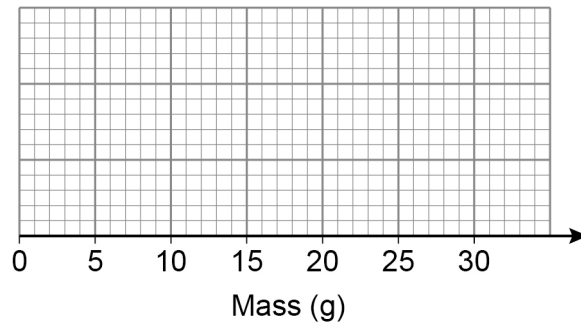

- 16 (b)** The lowest mass was 3 grams.
The highest mass was 28 grams.
Draw a box plot to represent the data.

[3 marks]

- 17** Circle the vector that translates the point $(-2, 7)$ to the point $(3, -1)$

[1 mark]

$$\begin{pmatrix} 5 \\ -6 \end{pmatrix}$$

$$\begin{pmatrix} 5 \\ -8 \end{pmatrix}$$

$$\begin{pmatrix} -5 \\ 8 \end{pmatrix}$$

$$\begin{pmatrix} -5 \\ 6 \end{pmatrix}$$

Turn over for the next question

Turn over ►



18 (a) Here is a triangle.

Not drawn
accurately

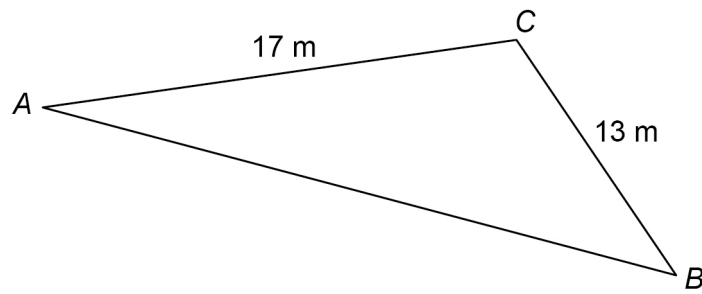

Give a reason why the length of side AB **cannot** be 35 m

[1 mark]



18 (b) Here is a different triangle.

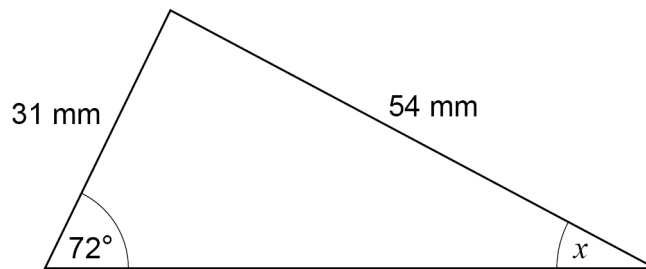

Not drawn
accurately

Leah tries to use the sine rule to work out the size of angle x .

Here are the first two lines of her working.

$$\frac{x}{\sin 31} = \frac{54}{\sin 72}$$

$$x = \frac{54 \sin 31}{\sin 72}$$

What error has she made in this working?

[1 mark]



- 19** Items made at a factory have to pass two checks.
- 90% pass the first check.
- The items that fail are scrapped.
- 99% of the items that pass the first check pass the second check.
- The items that fail are scrapped.

- 19 (a)** Complete the tree diagram.

[2 marks]

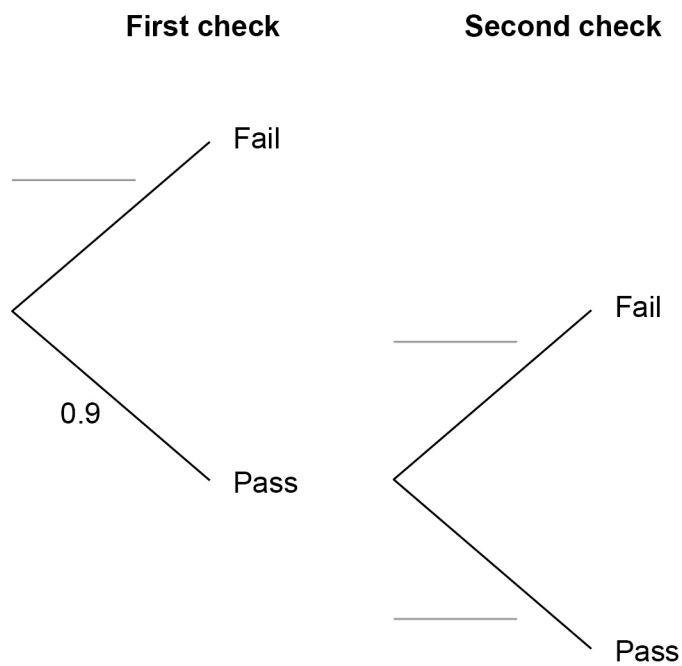

- 19 (b)** An item is chosen at random before the checks.
Work out the probability that the item is scrapped.

[3 marks]

Answer _____

- 20** Which **one** of these is a unit of density?
Circle your answer.

[1 mark] cm^2/g cm^3/g g/cm^2 g/cm^3 **Turn over for the next question****Turn over ►**

22 Work out the value of $\left(\frac{5}{7}\right)^{-2}$

Give your answer as a mixed number.

[3 marks]

Answer _____

23 Rearrange $y = \frac{1}{\sqrt{x+1}}$ to make x the subject.

[3 marks]

Answer _____



24 (b) $g(x) = 2x$ and $h(x) = \frac{x-1}{2}$

Circle the expression for $hg(x)$

[1 mark]

$$\frac{2x^2 - x}{2}$$

$$\frac{2x - 1}{2}$$

$$x^2 - x$$

$$x - 1$$

25

Show that $\frac{\sqrt{150} - \sqrt{6}}{\sqrt{2} \times \sqrt{3}}$ simplifies to an integer.

[3 marks]

Turn over for the next question

Turn over ►



27

The vertices of a regular hexagon lie on a circle with centre O and radius 5 cm

Not drawn
accurately

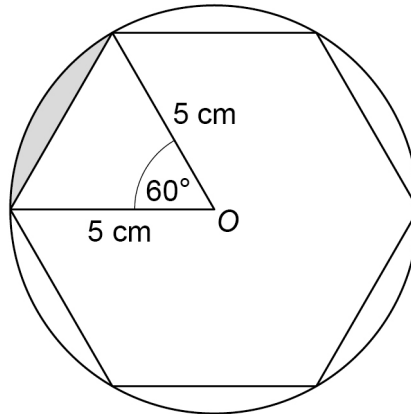

Work out the shaded area.

Give your answer in the form $\frac{a\pi - b\sqrt{c}}{12}$ where a , b and c are integers.

[4 marks]

Answer _____ cm²

7

Turn over ►



28 Here is the graph of $y = \cos x$ for $0^\circ \leq x \leq 360^\circ$

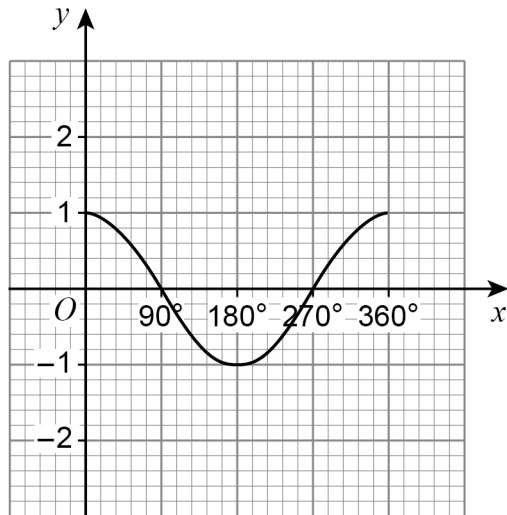

In parts (a) and (b) the graph of $y = \cos x$ is shown as a dashed line.

28 (a) On the grid below, draw the graph of $y = \cos(x - 90^\circ)$ for $0^\circ \leq x \leq 360^\circ$

[1 mark]

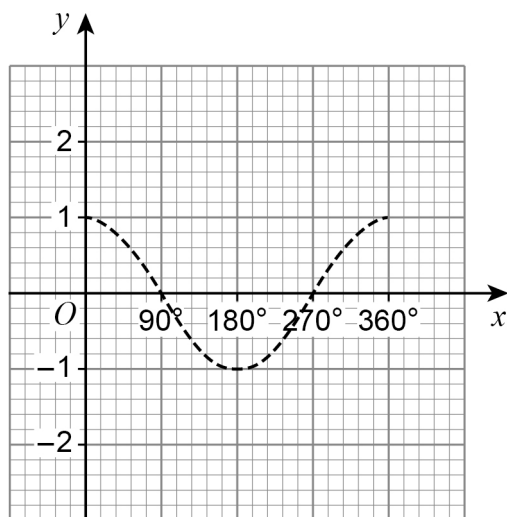

- 28 (b) On the grid below, draw the graph of $y = 1 + \cos x$ for $0^\circ \leq x \leq 360^\circ$

[1 mark]

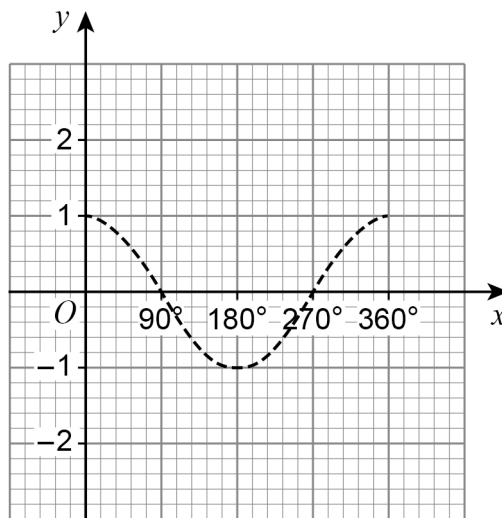

- 28 (c) Rita tries to draw the graph of $y = \cos(-x)$ for $0^\circ \leq x \leq 360^\circ$

Here is her graph.

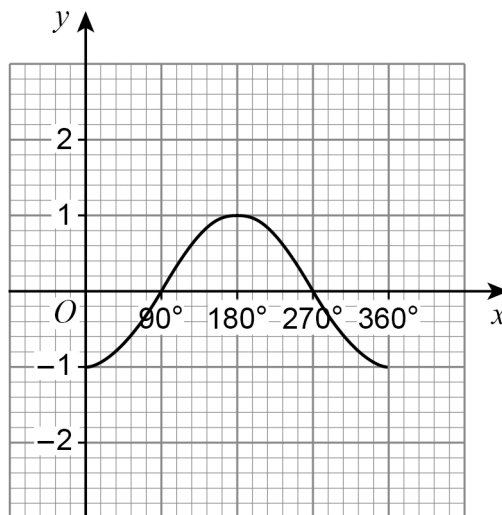

Give a reason why Rita's graph is incorrect.

[1 mark]

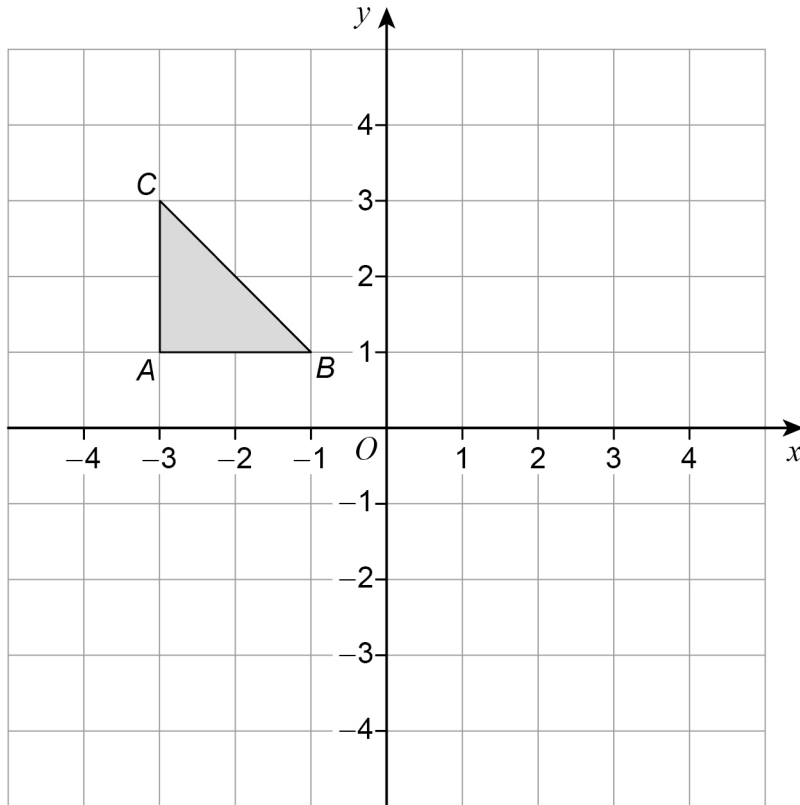

29

Here is triangle ABC on a grid.Describe a **single** transformation of the triangle so thatpoint B is invariantpoint A moves to $(1, 1)$ point C moves to $(1, -1)$ **[3 marks]**

END OF QUESTIONS